

DATA SHEET

SKY13317-373LF: 0.1-6.0 GHz pHEMT GaAs SP3T Switch

Applications

- 802.11 a/b/g/n WLAN networks
- Bluetooth® systems

Features

- Positive low voltage control: 0/1.9-5.0 V
- Low insertion loss: 0.5 dB @ 2.5 GHz, 0.9 dB @ 6 GHz
- High isolation: 25 dB up to 6 GHz
- Excellent linearity performance: P1dB = +29 dBm
- Miniature, ultra-thin MLP (8-pin, 1.5 x 1.5 mm) package (MSL1, 260 °C per JEDEC J-STD-020)

NEW

Skyworks Green™ products are RoHS (Restriction of Hazardous Substances)-compliant, conform to the EIA/EICTA/JEITA Joint Industry Guide (JIG) Level A guidelines, are halogen free according to IEC-61249-2-21, and contain <1,000 ppm antimony trioxide in polymeric materials.

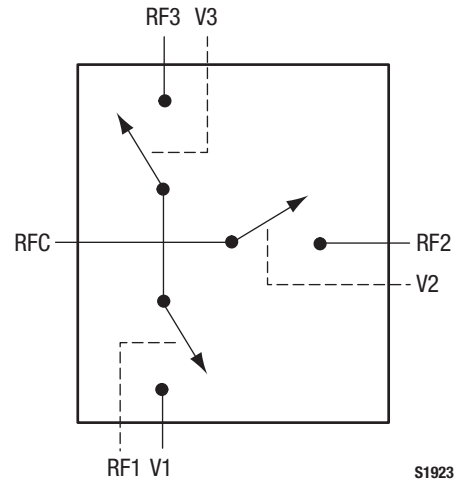

Figure 1. SKY13317-373LF Block Diagram

Description

The SKY13317-373LF is a GaAs pHEMT Single-Pole Triple-Throw (SP3T) antenna switch that operates in the 0.1 to 6.0 GHz frequency range. Switching between the antenna (RFC signal) and the RF1, RF2, and RF3 ports is accomplished with three control voltages.

The low loss, high isolation, high linearity, small size, and low cost make this switch ideal for all WLAN and Bluetooth systems operating in the 2.4 to 2.5 GHz and 4.9 to 5.9 GHz bands.

The SKY13317-373LF is manufactured in a compact, 1.5 x 1.5 mm, 8-pin Micro Leadframe (MLP) package. A functional block diagram is shown in Figure 1. The pin configuration and package are shown in Figure 2. Signal pin assignments and functional pin descriptions are provided in Table 1.

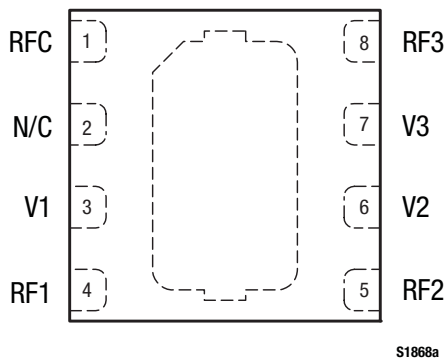

S1868a

Figure 2. SKY13317-373LF Pinout – 8-Pin MLP (Top View)

Table 1. SKY13317-373LF Signal Descriptions

| Pin # | Name | Description | Pin # | Name | Description |
|-------|------|--|-------|------|--|
| 1 | RFC | Antenna. DC blocking capacitor required. | 5 | RF2 | RF port 2. DC blocking capacitor required. |
| 2 | N/C | No connect | 6 | V2 | Switch logic control (see Table 4) |
| 3 | V1 | Switch logic control (see Table 4) | 7 | V3 | Switch logic control (see Table 4) |
| 4 | RF1 | RF port 1. DC blocking capacitor required. | 8 | RF3 | RF port 3. DC blocking capacitor required. |

Table 2. SKY13317-373LF Absolute Maximum Ratings

| Parameter | Symbol | Minimum | Typical | Maximum | Units |
|-----------------------|------------------|---------|---------|---------|-------|
| Input power @ 0/3 V | P _{IN} | | | +30 | dBm |
| Input power @ 0/5 V | P _{IN} | | | +30 | dBm |
| Operating voltage | V _{DD} | | | 8 | V |
| Operating temperature | T _{OP} | -40 | | +85 | °C |
| Storage temperature | T _{STG} | -65 | | +150 | °C |

Note: Exposure to maximum rating conditions for extended periods may reduce device reliability. There is no damage to device with only one parameter set at the limit and all other parameters set at or below their nominal value. Exceeding any of the limits listed here may result in permanent damage to the device.

CAUTION: Although this device is designed to be as robust as possible, Electrostatic Discharge (ESD) can damage this device. This device must be protected at all times from ESD. Static charges may easily produce potentials of several kilovolts on the human body or equipment, which can discharge without detection. Industry-standard ESD precautions should be used at all times.

Electrical and Mechanical Specifications

The absolute maximum ratings of the SKY13317-373LF are provided in Table 2. Electrical specifications are provided in Table 3.

The state of the SKY13317-373LF is determined by the logic provided in Table 4.

Table 3. SKY13317-373LF Electrical Specifications (Note 1)
(V_{HIGH} = 1.9 to 5.0 V, T_{OP} = +25 °C, Unless Otherwise Noted)

| Parameter | Symbol | Test Condition | Min | Typical | Max | Units |
|---|--------|--|-----|----------------|------|------------|
| Insertion loss | IL | RFC to RF1, RF2, RF3 | | | | |
| | | 0.1 to 1.0 GHz | | 0.40 | 0.45 | dB |
| | | 1.0 to 3.0 GHz | | 0.60 | 0.70 | dB |
| | | 3.0 to 6.0 GHz | | 0.80 | 1.20 | dB |
| | | 2.4 to 2.5 GHz | | 0.55 | 0.65 | dB |
| 4.9 to 5.9 GHz | | 0.80 | | dB | | |
| Isolation | ISO | RFC to RF1, RF2, RF3 | | | | |
| | | 0.1 to 1.0 GHz | 24 | 27 | dB | |
| | | 1.0 to 3.0 GHz | 22 | 25 | dB | |
| | | 3.0 to 6.0 GHz | 22 | 25 | dB | |
| | | 2.4 to 2.5 GHz | 22 | 25 | dB | |
| 4.9 to 5.9 GHz | | 25 | dB | | | |
| Return loss (insertion loss state) | IS111 | RFC to RF1, RF2, RF3 | | | | |
| | | 0.1 to 1.0 GHz | | 20 | dB | |
| | | 1.0 to 3.0 GHz | | 20 | dB | |
| | | 3.0 to 6.0 GHz | | 15 | dB | |
| | | 2.4 to 2.5 GHz | | 25 | dB | |
| 4.9 to 5.9 GHz | | 15 | dB | | | |
| Switching speed: Rise time Fall time On time Off time | G | 10/90% RF | | 50 | | ns |
| | | 90/10% RF | | 110 | | ns |
| | | 50% control to 90/10% RF | | 55 | | ns |
| | | 50% control to 90/10% RF | | 140 | | ns |
| Video feedthrough | | | | 50 | | mV |
| 1 dB input compression point | IP1 dB | 900 to 2450 MHz | | | | |
| | | V _{LOW} = 0 V, V _{HIGH} = 3.3 V V _{LOW} = 0 V, V _{HIGH} = 1.9 V | | +29.0 +18.5 | | dBm dBm |
| 3 rd Order Input Intercept Point | IIP3 | 900 to 2450 MHz, ΔF = 1 MHz, P _{IN} = +17 dBm/tone | | | | |
| | | V _{LOW} = 0 V, V _{HIGH} = 2.1 V V _{LOW} = 0 V, V _{HIGH} = 3.3 V | | +33 +50 | | dBm dBm |
| Control voltage | | V _{LOW} = 0 to 0.25 V @ 5 μA typical | | 0 | | V |
| | | V _{HIGH} = 1.9 to 5.0 V @ 10 μA typical | | 3.3 | | V |

Note 1: Performance is guaranteed only under the conditions listed in this Table.

Table 4. SKY13317-373LF Truth Table

| Low Insertion Loss Path | V1 (Pin 3) | V2 (Pin 6) | V3 (Pin 7) |
|-------------------------|------------|------------|------------|
| RFC to RF1 | High | Low | Low |
| RFC to RF2 | Low | High | Low |
| RFC to RF3 | Low | Low | High |

Note: "High" = 1.9 to 5.0 V. "Low" = 0 to 0.25 V. Any state other than described in this Table places the switch into an undefined state. An undefined state will not damage the device.

Typical Performance Characteristics

(RFC to RF1, RF2, RF3 (0, 3.3 V), $T_{OP} = +25\text{ }^{\circ}\text{C}$, Characteristic Impedance $[Z_0] = 50\ \Omega$, Unless Otherwise Noted)

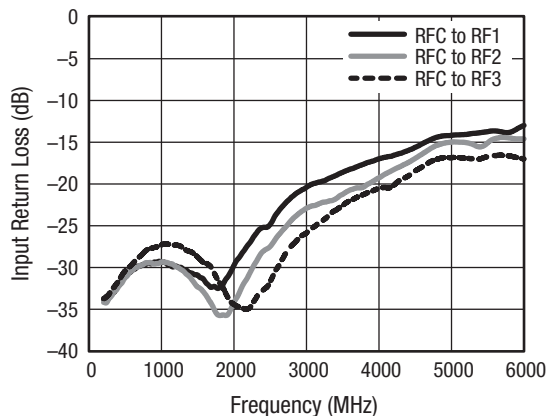

Figure 3. Input Return Loss (Insertion Loss State) vs Frequency

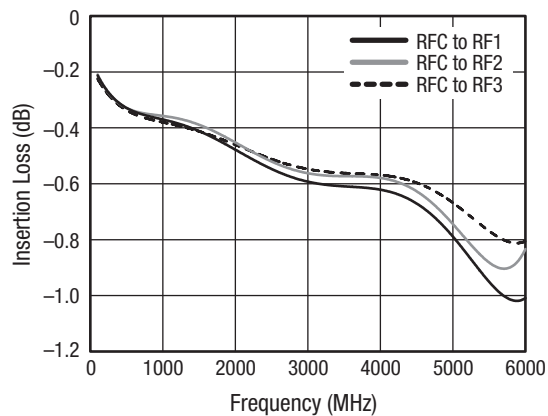

Figure 4. Insertion Loss vs Frequency

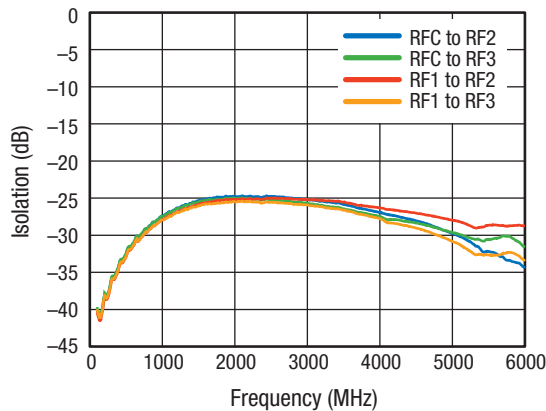

Figure 5. Isolation vs Frequency (RFC to RF1 Insertion Loss State)

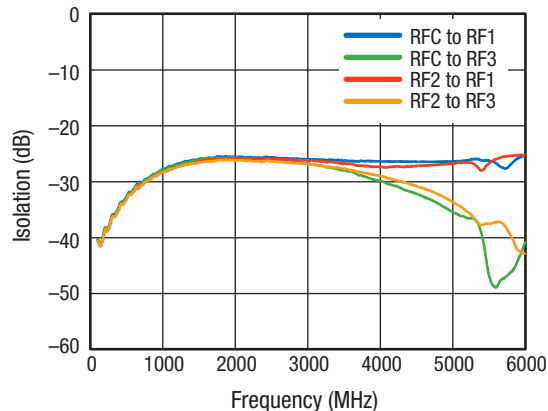

Figure 6. Isolation vs Frequency (RFC to RF2 Insertion Loss State)

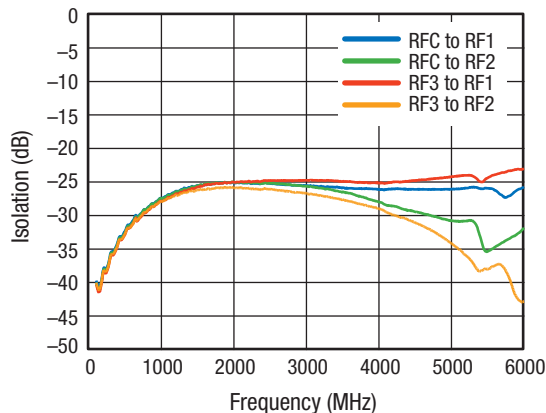

Figure 7. Isolation vs Frequency (RFC to RF3 Insertion Loss State)

Evaluation Board Description

The SKY13317-373LF Evaluation Board is used to test the performance of the SKY13317-373LF SPDT Switch. An Evaluation Board schematic diagram is provided in Figure 8. An assembly drawing for the Evaluation Board is shown in Figure 9.

Package Dimensions

The PCB layout footprint for the SKY13317-373LF is provided in Figure 10. Typical case markings are shown in Figure 11. Package dimensions for the 8-pin MLP are shown in Figure 12, and tape and reel dimensions are provided in Figure 13.

Package and Handling Information

Instructions on the shipping container label regarding exposure to moisture after the container seal is broken must be followed. Otherwise, problems related to moisture absorption may occur when the part is subjected to high temperature during solder assembly.

THE SKY13317-373LF is rated to Moisture Sensitivity Level 1 (MSL1) at 260 °C. It can be used for lead or lead-free soldering.

Care must be taken when attaching this product, whether it is done manually or in a production solder reflow environment. Production quantities of this product are shipped in a standard tape and reel format. For packaging details, refer to the Skyworks Application Note, *Discrete Devices and IC Switch/Attenuators Tape and Reel Package Orientation*, document number 200083.

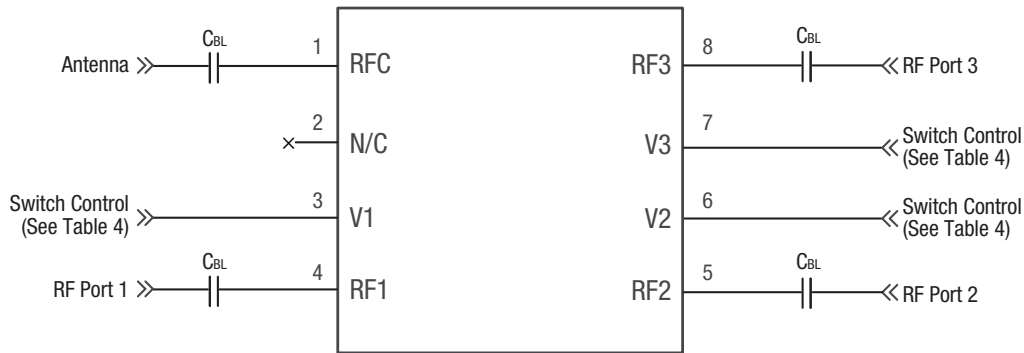

Note: $C_{BL} = 47\text{ pF}$ for $>500\text{ MHz}$ operation; 220 pF for $50\text{ to }500\text{ MHz}$ operation.
Higher values recommended for lower frequency operation.
Exposed paddle must be grounded.

S1925

Figure 8. SKY13317-373LF Evaluation Board Schematic

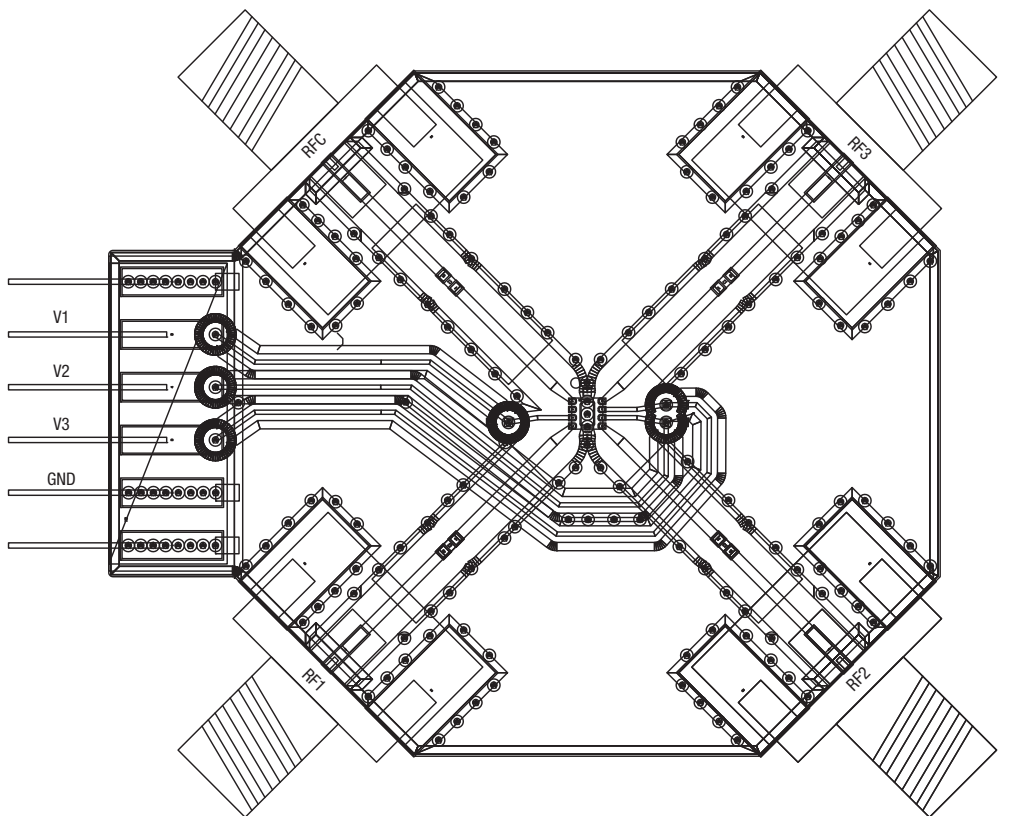

S1926

Figure 9. SKY13317-373LF Evaluation Board Assembly Diagram

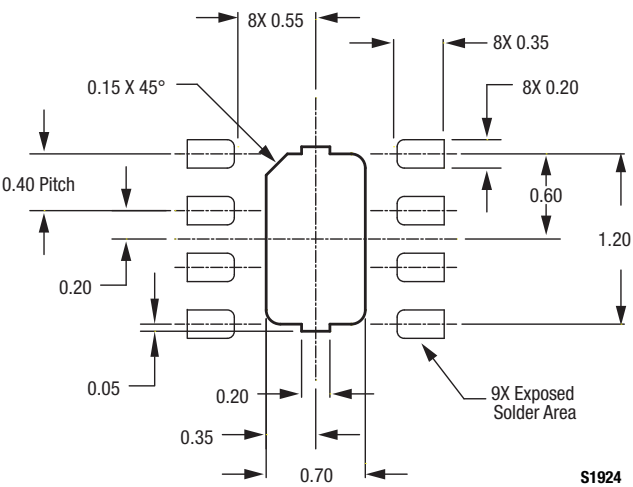

S1924

Figure 10. SKY13317-373LF PCB Layout Footprint (Top View)

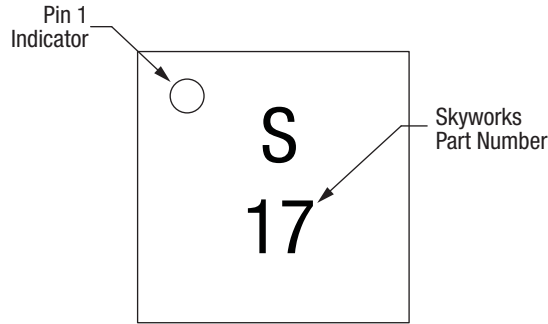
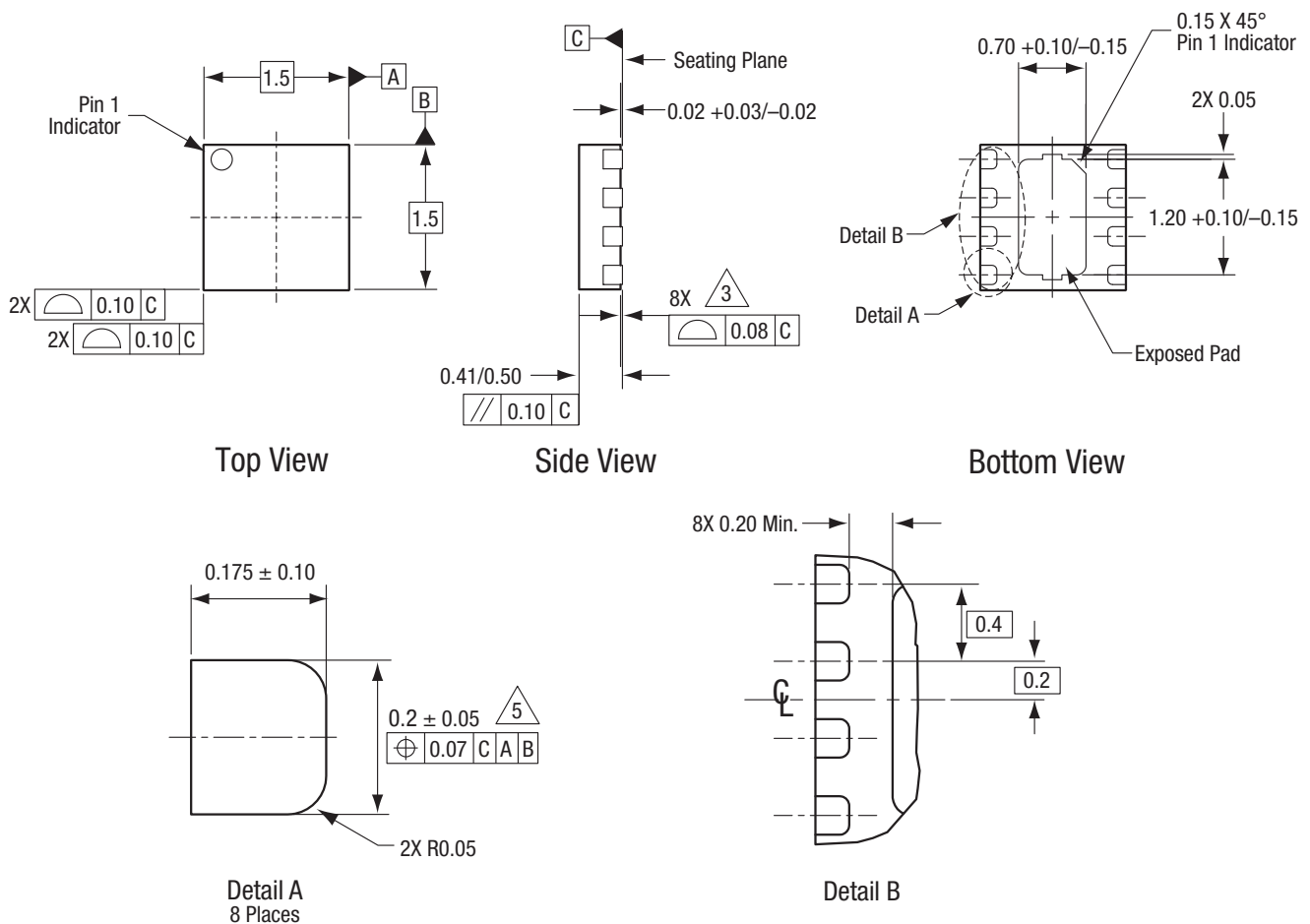

Figure 11. Typical Case Markings (Top View)



All measurements are in millimeters.
 Dimensioning and tolerancing according to ASME Y14.5M-1994.
 Coplanarity applies to the exposed heat sink slug as well as the terminals.
 Plating requirement per source control drawing (SCD) 2504.
 Dimension applies to metalized terminal and is measured between 0.15 mm and 0.30 mm from terminal tip.

S1869

Figure 12. SKY13317-373LF 8-Pin MLP Package Dimensions

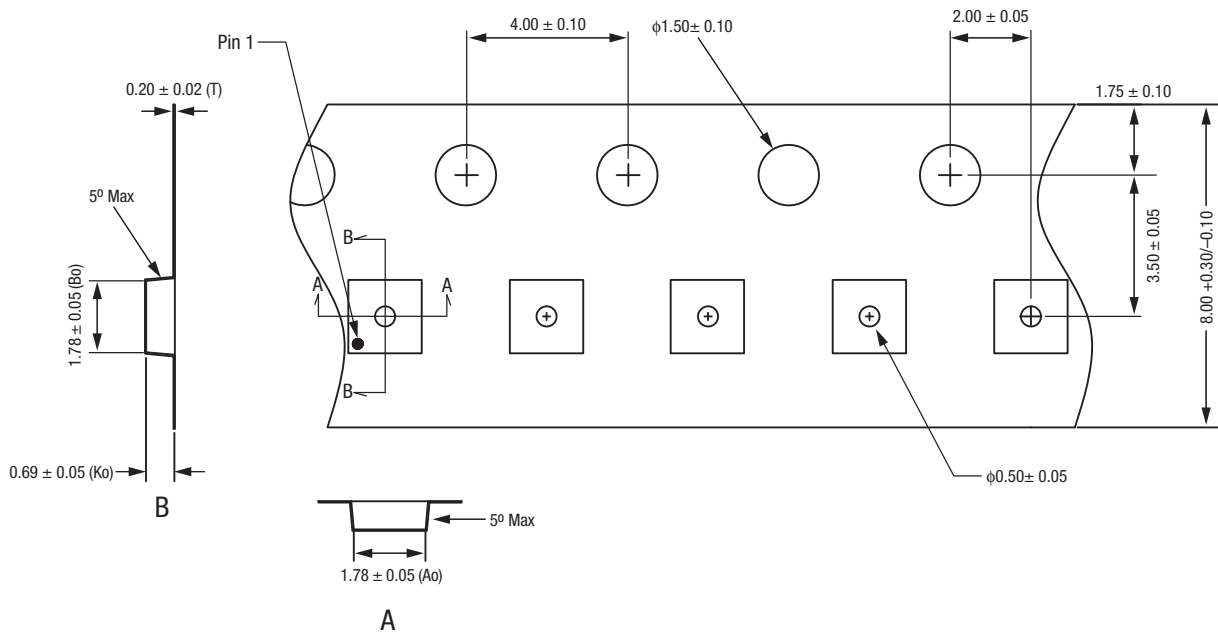

Notes:

1. Carrier tape: black conductive polycarbonate or polystyrene.
2. Cover tape material: transparent conductive PSA.
3. Cover tape size: 5.4 mm width.
4. All measurements are in millimeters.

S1382

Figure 13. SKY13317-373LF Tape and Reel Dimensions

Ordering Information

| Model Name | Manufacturing Part Number | Evaluation Board Part Number |
|----------------------------|---------------------------|------------------------------|
| SKY13317-373LF SP3T Switch | SKY13317-373LF | SK41105-1 |

Copyright © 2008, 2009, 2010 Skyworks Solutions, Inc. All Rights Reserved.

Information in this document is provided in connection with Skyworks Solutions, Inc. ("Skyworks") products or services. These materials, including the information contained herein, are provided by Skyworks as a service to its customers and may be used for informational purposes only by the customer. Skyworks assumes no responsibility for errors or omissions in these materials or the information contained herein. Skyworks may change its documentation, products, services, specifications or product descriptions at any time, without notice. Skyworks makes no commitment to update the materials or information and shall have no responsibility whatsoever for conflicts, incompatibilities, or other difficulties arising from any future changes.

No license, whether express, implied, by estoppel or otherwise, is granted to any intellectual property rights by this document. Skyworks assumes no liability for any materials, products or information provided hereunder, including the sale, distribution, reproduction or use of Skyworks products, information or materials, except as may be provided in Skyworks Terms and Conditions of Sale.

THE MATERIALS, PRODUCTS AND INFORMATION ARE PROVIDED "AS IS" WITHOUT WARRANTY OF ANY KIND, WHETHER EXPRESS, IMPLIED, STATUTORY, OR OTHERWISE, INCLUDING FITNESS FOR A PARTICULAR PURPOSE OR USE, MERCHANTABILITY, PERFORMANCE, QUALITY OR NON-INFRINGEMENT OF ANY INTELLECTUAL PROPERTY RIGHT; ALL SUCH WARRANTIES ARE HEREBY EXPRESSLY DISCLAIMED. SKYWORKS DOES NOT WARRANT THE ACCURACY OR COMPLETENESS OF THE INFORMATION, TEXT, GRAPHICS OR OTHER ITEMS CONTAINED WITHIN THESE MATERIALS. SKYWORKS SHALL NOT BE LIABLE FOR ANY DAMAGES, INCLUDING BUT NOT LIMITED TO ANY SPECIAL, INDIRECT, INCIDENTAL, STATUTORY, OR CONSEQUENTIAL DAMAGES, INCLUDING WITHOUT LIMITATION, LOST REVENUES OR LOST PROFITS THAT MAY RESULT FROM THE USE OF THE MATERIALS OR INFORMATION, WHETHER OR NOT THE RECIPIENT OF MATERIALS HAS BEEN ADVISED OF THE POSSIBILITY OF SUCH DAMAGE.

Skyworks products are not intended for use in medical, lifesaving or life-sustaining applications, or other equipment in which the failure of the Skyworks products could lead to personal injury, death, physical or environmental damage. Skyworks customers using or selling Skyworks products for use in such applications do so at their own risk and agree to fully indemnify Skyworks for any damages resulting from such improper use or sale.

Customers are responsible for their products and applications using Skyworks products, which may deviate from published specifications as a result of design defects, errors, or operation of products outside of published parameters or design specifications. Customers should include design and operating safeguards to minimize these and other risks. Skyworks assumes no liability for applications assistance, customer product design, or damage to any equipment resulting from the use of Skyworks products outside of stated published specifications or parameters.

Skyworks, the Skyworks symbol, and "Breakthrough Simplicity" are trademarks or registered trademarks of Skyworks Solutions, Inc., in the United States and other countries. Third-party brands and names are for identification purposes only, and are the property of their respective owners. Additional information, including relevant terms and conditions, posted at www.skyworksinc.com, are incorporated by reference.